

Control of Systems with Infinitely Many Unstable Modes and Strongly Stabilizing Controllers Achieving a Desired Sensitivity

Suat Gümüşsoy and Hitay Özbay
Collaborative Center of Control Science
Department of Electrical Engineering
The Ohio State University
2015 Neil Avenue, Columbus, OH 43210

MTNS 2002

Abstract

In this paper we consider a class of linear time invariant systems with infinitely many unstable modes. By using the parameterization of all stabilizing controllers, we show that \mathcal{H}^∞ controllers for such systems can be computed using the techniques developed earlier for infinite dimensional plants with finitely many unstable modes. We illustrate connections between the problem solved here and an indirect method for strongly stabilizing \mathcal{H}^∞ controller design for systems with time delays.

1 Introduction

If a stable controller results in a stable feedback system, then it is said to be a strongly stabilizing controller, [1]. There are many practical applications where strongly stabilizing \mathcal{H}^∞ controllers are desired, see e.g. [2, 3, 4, 5, 6, 7, 8, 9] and their references. These papers on \mathcal{H}^∞ strong stabilization deal with direct design methods for finite dimensional plants. The problem is still an open research area for infinite dimensional plants.

It is known that for a certain class of time delay systems the optimal \mathcal{H}^∞ controllers designed for sensitivity minimization lead to controllers with infinitely many unstable modes, [10, 11]. An indirect way to obtain a strongly stabilizing controller, in this case, is to internally stabilize the optimal sensitivity minimizing \mathcal{H}^∞ controller, while keeping the sensitivity deviation from the optimum within a desired bound. The proposed scheme is illustrated in Figure 1: the objective is to have a stable feedback system, and to minimize the weighted sensitivity function $WS := W(1 + PK)^{-1}$, with a stable K . We will assume that for given W and P , the optimal \mathcal{H}^∞ controller C_{opt} is determined. Then, F will be designed to yield a stable K , such that the feedback system remains stable, and WS is “relatively close” to the optimal weighted sensitivity $WS_{\text{opt}} := W(1 + PC_{\text{opt}})^{-1}$. See Section 3 for more precise definition of this problem.

When the plant, P , contains a time delay, and the sensitivity weight W is bi-proper, the indirect approach outlined above requires internal stabilization of C (which contains infinitely

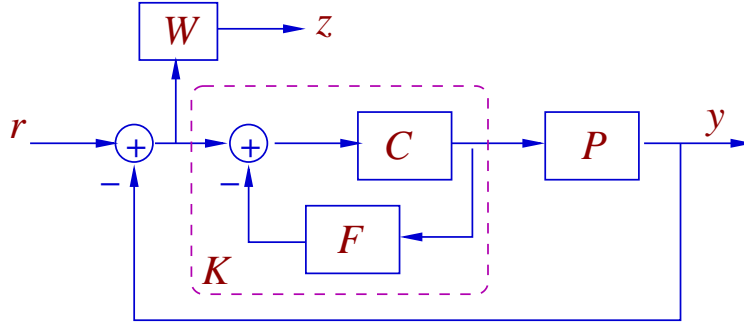

Figure 1: (i) $F = 0$: the weighted sensitivity is \mathcal{H}^∞ optimal; (ii) $F \neq 0$: the controller K is stable.

many unstable modes) by F . In the next section we will see a solution to the two-block \mathcal{H}^∞ control problem involving a plant with infinitely many poles in the open right half plane. Then, the results of Section 2 will be used in Section 3 to derive sufficient conditions for solvability of the stable \mathcal{H}^∞ controller design problem considered here for systems with time delays. Concluding remarks are made in Section 4.

2 \mathcal{H}^∞ Control of Systems with Infinitely Many Unstable Modes

In order to be consistent with the notation used in the rest of the paper, in this section P_C and C_F denote the “plant” and the “controller” respectively. In the next section P_C will be the optimal \mathcal{H}^∞ sensitivity minimizing controller, and C_F will be F . Assume that

$$P_C(s) = \frac{N(s)}{M(s)}$$

where M is inner and infinite dimensional (it has infinitely many zeros in \mathbb{C}_+ , that are unstable poles of P_C), $N = N_i N_o$ with N_i being inner finite dimensional, and $N_o, N_o^{-1} \in \mathcal{H}^\infty$.

Following the controller parameterization of Smith, [12], we form the Bezout equation, in terms of $X, Y \in \mathcal{H}^\infty$

$$NX + MY = 1 \tag{2.1}$$

i.e.

$$X(s) = \left(\frac{1 - M(s)Y(s)}{N_i(s)} \right) N_o^{-1}(s).$$

Let z_1, \dots, z_n be the zeros of $N_i(s)$ in \mathbb{C}_+ , and assume that they are distinct. Then, there are finitely many interpolation conditions on $Y(s)$ for $X(s)$ to be stable, i.e.

$$Y(z_i) = \frac{1}{M(z_i)}.$$

Thus by Lagrange interpolation, we can find a finite dimensional $Y \in \mathcal{H}^\infty$ and infinite dimensional $X \in \mathcal{H}^\infty$ satisfying (2.1), and all controllers stabilizing the feedback system formed by the plant P_C and the controller C_F are parameterized as follows, [12],

$$C_F(s) = \frac{X(s) + M(s)Q(s)}{Y(s) - N(s)Q(s)} \quad \text{where } Q(s) \in \mathcal{H}^\infty \text{ and } (Y(s) - N(s)Q(s)) \neq 0 \quad (2.2)$$

Note that if our concern is simply stabilization of P_C , then we can select $Q(s) = 0$ and $C_F(s) = \frac{X(s)}{Y(s)}$ is a stabilizing controller. But in the next section we will need to solve the following two block \mathcal{H}^∞ problem. First note that,

$$\begin{aligned} (1 + P_C(s)C_F(s))^{-1} &= M(Y(s) - N(s)Q(s)) \\ P_C(s)C_F(s)(1 + P_C(s)C_F(s))^{-1} &= N(s)(X(s) + M(s)Q(s)). \end{aligned} \quad (2.3)$$

Then, in terms of the free controller parameter Q , we define the \mathcal{H}^∞ problem as finding

$$\inf_{C_F \text{ stabilizes } P_C} \left\| \begin{bmatrix} W_1(1 + P_C C_F)^{-1} \\ W_2 P_C C_F (1 + P_C C_F)^{-1} \end{bmatrix} \right\|_\infty = \inf_{Q \in \mathcal{H}^\infty} \left\| \begin{bmatrix} W_1(Y - NQ) \\ W_2 N(X + MQ) \end{bmatrix} \right\|_\infty. \quad (2.4)$$

where W_1 and W_2 are given finite dimensional (rational) weights. By using the Bezout equation, we can define

$$\begin{aligned} \gamma(Q) &:= \left\| \begin{bmatrix} W_1 Y - W_1 N Q \\ W_2 N \left(\frac{1 - M Y}{N} \right) + W_2 M N Q \end{bmatrix} \right\|_\infty \\ &= \left\| \begin{bmatrix} W_1 Y - W_1 N_i(N_o Q) \\ W_2(1 - M Y) + W_2 M N Q \end{bmatrix} \right\|_\infty \\ &= \left\| \begin{bmatrix} W_1(Y - N_i(N_o Q)) \\ W_2(1 - M(Y - N_i(N_o Q))) \end{bmatrix} \right\|_\infty \end{aligned} \quad (2.5)$$

In summary, the \mathcal{H}^∞ optimization problem reduces to

$$\inf_{Q \in \mathcal{H}^\infty} \gamma(Q) = \inf_{Q_1 \in \mathcal{H}^\infty} \left\| \begin{bmatrix} W_1(Y - N_i Q_1) \\ W_2(1 - M(Y - N_i Q_1)) \end{bmatrix} \right\|_\infty \quad (2.6)$$

where $Q_1 = N_o Q$, and note that $W_1(s), W_2(s), N_i(s), Y(s)$ are rational functions, and $M(s)$ is inner infinite dimensional.

The problem defined in (2.6) has the same structure as the problem dealt in Chapter 5 of the book [13] (by Foias, Özbay and Tannenbaum, (FÖT)), where skew Toeplitz approach has been used for computing \mathcal{H}^∞ optimal controllers for infinite dimensional systems with finitely many poles in \mathbb{C}_+ . Our case is the dual of the problem solved in [13], that is there are infinitely many poles in \mathbb{C}_+ , but the number of zeros in \mathbb{C}_+ is finite. Thus by mapping the variables as shown below, we can use the results of [13] to solve our problem:

$$W_1^{F\ddot{O}T}(s) = W_2(s)$$

$$W_2^{F\ddot{O}T}(s) = W_1(s)$$

$$X^{F\ddot{O}T}(s) = Y(s)$$

$$M_d^{F\ddot{O}T} = N_i(s)$$

$$M_n^{F\ddot{O}T}(s) = M(s)$$

$$N_o^{F\ddot{O}T}(s) = N_o(s).$$

If we consider the one block problem only, with $W_2 = 0$, then the minimization of $\|W_1(Y - N_i Q_1)\|_\infty$ is simply a finite dimensional problem. On the other hand, the one block problem obtained by putting $W_1 = 0$, i.e. minimizing $\|W_2(1 - M(Y - N_i Q_1))\|_\infty$ over $Q_1 \in \mathcal{H}^\infty$, is an infinite dimensional problem.

3 Stable \mathcal{H}^∞ Controllers for Delay Systems: Suboptimal Sensitivity

In this section we investigate the indirect method of obtaining a strongly stabilizing controller for systems with time delays, subject to a bound on the deviation of the sensitivity from its optimal value. First we examine the optimal sensitivity problem for stable delay systems and illustrate that the corresponding optimal controller has the structure of P_C introduced in Section 2.

3.1 Optimal Sensitivity Problem for Delay Systems

Consider the feedback system shown in Figure 1, where $P(s) = e^{-hs}N_p(s)$ and $W(s) = \frac{1+\alpha s}{s+\beta}$. We assume that $N_p, N_p^{-1} \in \mathcal{H}^\infty$. By using the method developed in [13, 14], we calculate the optimal controller, $C_{opt}(s)$, minimizing the weighted sensitivity $W(1 + PC)^{-1}$ over all stabilizing controllers, as follows. The smallest γ satisfying the phase equation given below is the optimal (smallest achievable) sensitivity level:

$$h\omega_\gamma + \tan^{-1} \alpha\omega_\gamma + \tan^{-1} \frac{\omega_\gamma}{\beta} = \pi \quad (3.7)$$

where $\omega_\gamma = \sqrt{\frac{1-\gamma^2\beta^2}{\gamma^2-\alpha^2}}$, and $\alpha < \gamma < \frac{1}{\beta}$. Once γ_{opt} is computed as above, the corresponding optimal controller is

$$C_{opt}(s) = \frac{(1 - \gamma_{opt}^2\beta^2) + (\gamma_{opt}^2 - \alpha^2)s^2}{\gamma_{opt}(\beta + s)(1 + \alpha s)} \frac{N_p^{-1}(s)}{1 + \gamma_{opt} \left(\frac{\beta - s}{1 + \alpha s} \right) e^{-hs}}. \quad (3.8)$$

Also, define the optimal sensitivity function as $S_{opt}(s) = (1 + P(s)C_{opt}(s))^{-1}$, then,

$$S_{opt}(j\omega) = \frac{1 + \left(\frac{\gamma_{opt}(\beta - j\omega)}{1 + \alpha j\omega} \right) e^{-jh\omega}}{1 + \left(\frac{1 - \alpha j\omega}{\gamma_{opt}(\beta + j\omega)} \right) e^{-jh\omega}}. \quad (3.9)$$

In [10], it was mentioned that \mathcal{H}^∞ -optimal controllers may have infinitely many right half plane poles. Here we will give a proof based on elementary Nyquist theory: if $S_{opt}^{-1}(j\omega)$ encircles the origin infinitely many times, we can say that $C_{opt}(s)$ has infinitely many right hand poles, because $P(s)$ does not have any right half plane poles. For $s = j\omega$ as $\omega \rightarrow \infty$, we have

$$S_{opt}^{-1}(j\omega) \rightarrow \frac{1 - \frac{\alpha}{\gamma_{opt}} e^{-jh\omega}}{1 - \frac{\gamma_{opt}}{\alpha} e^{-jh\omega}}$$

and $|S_{opt}^{-1}(j\omega)| \rightarrow \frac{\alpha}{\gamma_{opt}}$. Since $\alpha < \gamma_{opt} < \frac{1}{\beta}$, we can say that $|S_{opt}^{-1}(j\omega)|$ has constant magnitude between 0 and 1 for sufficiently large ω . For $\omega_k = \frac{2\pi k}{h}$, as $k \rightarrow \infty$ the phase of $S_{opt}^{-1}(j\omega_k)$ tends to $-\pi$. In other words, $S_{opt}^{-1}(j\omega)$ intersects negative part of the real axis near $\omega_k = \frac{2\pi k}{h}$, as $k \rightarrow \infty$. Similarly, $S_{opt}^{-1}(j\omega)$ intersects positive part of the real axis near $\omega_k = \frac{(2k+1)\pi}{h}$ as $k \rightarrow \infty$. Thus $S_{opt}^{-1}(j\omega)$ encircles the origin infinitely many times, which means that $C_{opt}(s)$ has infinitely many poles in \mathbb{C}_+ .

Remark. Let $m_1(j\omega) = \left(\frac{\beta-j\omega}{\beta+j\omega}\right) e^{-jh\omega}$, $m_2(j\omega) = \left(\frac{1-\alpha j\omega}{1+\alpha j\omega}\right) e^{-jh\omega}$ and $g(j\omega) = \gamma_{opt} \left(\frac{\beta+j\omega}{1+\alpha j\omega}\right)$. Then,

$$W(j\omega)S_{opt}(j\omega) = \gamma_{opt} \left(\frac{g^{-1}(j\omega) + m_1(j\omega)}{1 + g^{-1}(j\omega)m_2(j\omega)} \right) = \gamma_{opt} \left(\frac{1 + g(j\omega)m_1(j\omega)}{g(j\omega) + m_2(j\omega)} \right)$$

and hence $|W(j\omega)S_{opt}(j\omega)| = \gamma_{opt}$ as expected.

3.2 Sensitivity Deviation Problem

Recall that the \mathcal{H}^∞ optimal performance level was defined as

$$\gamma_0 := \gamma_{opt} = \inf_{C \text{ stab. } P} \|W(1 + PC)^{-1}\|_\infty$$

where $W(s) = \frac{1+\alpha s}{s+\beta}$, with $\alpha > 0$, $\beta > 0$, $\alpha\beta < 1$, and $P(s) = N_p(s)M_p(s)$, with $N_p, N_p^{-1} \in \mathcal{H}^\infty$, and M_p is inner and infinite dimensional, e.g. $M_p(s) = e^{-hs}$. We have obtained the optimal controller for the sensitivity minimization problem in (3.8).

Claim: The optimal \mathcal{H}^∞ controller is in the form

$$C_{opt}(s) = \frac{N_p^{-1}(s)N_c(s)}{D_c(s)} \tag{3.10}$$

where D_c is inner infinite dimensional and $N_c, N_c^{-1} \in \mathcal{H}^\infty$.

It is easy to verify this claim by comparing (3.8) with (3.10): we see that

$$N_c(s) = \frac{\gamma_{opt}^{-2} W^2(s)m_2(s) - m_1(s)}{1 + \gamma_{opt}^{-1} W(s)m_2(s)} = \frac{1}{\gamma_{opt}^2(\beta + s)^2} \frac{(1 - \gamma_{opt}^2\beta^2) + (\gamma_{opt}^2 - \alpha^2)s^2}{1 + \gamma_{opt}^{-1} \left(\frac{1-\alpha s}{\beta+s}\right) e^{-hs}} \tag{3.11}$$

$$\begin{aligned}
D_c(s) &= \frac{\gamma_{opt}^{-1}W(s) + m_1(s)}{1 + \gamma_{opt}^{-1}W(s)m_2(s)} = \gamma_{opt}^{-1}W(s) \left(\frac{1 + m_1(s)\gamma_{opt}W^{-1}(s)}{1 + m_2(s)\gamma_{opt}^{-1}W(s)} \right) \\
&= \gamma_{opt}^{-1}W(s)(1 + P(s)C_{opt}(s))^{-1} = D_c(s) = \frac{\left(\frac{\beta-s}{\beta+s}\right) e^{-hs} + \gamma_0^{-1} \left(\frac{1+\alpha s}{\beta+s}\right)}{1 + \gamma_0^{-1} \left(\frac{1-\alpha s}{\beta+s}\right) e^{-hs}} \quad (3.12)
\end{aligned}$$

where $m_1(s) = \left(\frac{\beta-s}{\beta+s}\right) e^{-hs}$, $m_2(s) = \left(\frac{1-\alpha s}{1+\alpha s}\right) e^{-hs}$. Note that $N_c(s)$ has no right half poles or zeros (it has only two imaginary axis poles that are cancelled by the zeros at the same locations). Therefore $N_c, N_c^{-1} \in \mathcal{H}^\infty$. Also, it is easy to check that D_c is inner and infinite dimensional.

Note that,

$$D_c = \gamma_0^{-1}W S_0 = \gamma_0^{-1}W(1 + PC_{opt})^{-1} = \left(\gamma_0^{-1}W \frac{D_c}{D_c + M_p N_c} \right).$$

Our goal is to have a stable controller K , by an appropriate selection of F :

$$K(s) = \frac{C_{opt}(s)}{1 + F(s)C_{opt}(s)}.$$

At the same time we would like to have the resulting sensitivity function,

$$S(s) = (1 + P(s)K(s))^{-1} = \left(1 + M_p(s)N_p(s) \frac{N_p^{-1}(s) \frac{N_c(s)}{D_c(s)}}{1 + F(s)N_p^{-1}(s) \frac{N_c(s)}{D_c(s)}} \right)^{-1}, \quad (3.13)$$

to be close to the optimal sensitivity, $S_{opt} = (1 + PC_{opt})^{-1}$. By the parameterization of the set of all stabilizing controllers for C_{opt} [12], F can be written as,

$$F(s) = \frac{X(s) + D_c(s)Q(s)}{Y(s) - N_p^{-1}(s)N_c(s)Q(s)}$$

with $N_p^{-1}(s)N_c(s)X(s) + D_c(s)Y(s) = 1$ which can be solved as $Y = 0$ and $X = N_c^{-1}N_p$ where $Q \in \mathcal{H}^\infty$, $Q(s) \neq 0$. Then, in terms of the design parameter Q , the functions $F(s)$, $K(s)$ and $S(s)$ can be re-written as,

$$F(s) = -\frac{N_c^{-1}(s)N_p(s) + D_c(s)Q(s)}{N_p^{-1}(s)N_c(s)Q(s)} = -(Q^{-1}(s) + C_{opt}^{-1}(s)) \quad (3.14)$$

$$K(s) = \frac{C_{opt}(s)}{1 - C_{opt}(s)(Q^{-1}(s) + C_{opt}^{-1}(s))} = -Q(s) \quad (3.15)$$

$$S(s) = (1 + M_p(s)N_p(s)(-Q(s)))^{-1}. \quad (3.16)$$

Also, sensitivity function $S(s)$ should be stable. We can define the relative deviation of the sensitivity as $\|W \left(\frac{S_0 - S}{S}\right)\|_\infty$, then minimizing this deviation over $Q \in \mathcal{H}^\infty$, $Q(s) \neq 0$ is equivalent to

$$\gamma_{1,opt} = \inf_{Q \in \mathcal{H}^\infty} \left\| W \left(\frac{S_0 - S}{S} \right) \right\|_\infty = \inf_{Q \in \mathcal{H}^\infty} \left\| W \left(-\frac{(M_p N_c)(1 + D_c N_p^{-1} N_c^{-1} Q)}{D_c + M_p N_c} \right) \right\|_\infty. \quad (3.17)$$

Note that, $|D_c(j\omega) + M_p(j\omega)N_c(j\omega)| = |\gamma_0^{-1}W(j\omega)|$ as shown before. Then,

$$\gamma_{1,opt} = \inf_{\widehat{Q} \in \mathcal{H}^\infty} \|\gamma_0 N_c(1 + D_c \widehat{Q})\|_\infty \quad (3.18)$$

where $\widehat{Q} = N_p N_c^{-1} Q$. For stability of the feedback system formed by the resulting controller K and the original plant P , we also want the sensitivity function, $S = (1 - M_p N_p Q)^{-1}$ to be stable. Once the optimal Q is determined from (3.18), a sufficient condition for stability of S (and hence the original feedback system) can be determined as

$$|N_p(j\omega)| < |Q(j\omega)|^{-1} \quad \forall \omega \quad (3.19)$$

Note that problem defined in (3.18) is equivalent to a sensitivity minimization with an infinite dimensional ‘‘weight’’ $\gamma_0 N_c$ for a stable infinite dimensional ‘‘plant’’ D_c . For the case where both the plant and the weight are infinite dimensional, sensitivity minimization problem is difficult to solve. So, we propose to approximate the weight by a finite dimensional upper bound function: find a stable rational weight W_1 such that $|\gamma_0 N_c(j\omega)| \leq |W_1(j\omega)|$. We suggest an envelope which is in the form,

$$W_1(s) = \gamma_0 K \frac{s + \alpha_1}{s + \beta_1},$$

where

$$\begin{aligned} K &= 1 + \alpha \gamma_{opt}^{-1} \\ \beta_1 &= \beta(\gamma_{opt} + \alpha)(1 - \gamma_{opt}\beta)^{-1} \alpha_1 \end{aligned}$$

and α_1 is determined in some optimal fashion, the details are in the full version of the paper, [15].

Then, we can solve the one following block problem as in Section 3.1

$$\gamma_{1,opt} \leq \gamma_{2,opt} = \inf_{\widehat{Q} \in \mathcal{H}^\infty} \|W_1(1 + D_c \widehat{Q})\|_\infty. \quad (3.20)$$

Note that $\gamma_{2,opt}$ is the smallest value of γ_2 , in the range $\gamma_0 K < \gamma_2 < (\gamma_0 K) \frac{\alpha_1}{\beta_1}$, satisfying

$$\begin{aligned} \pi &= \tan^{-1} \left(\frac{\omega}{\alpha_1} \right) + \tan^{-1} \left(\frac{\omega}{\beta_1} \right) + h\omega + \tan^{-1} \left(\frac{\gamma_0^{-1} \alpha \omega \cos(h\omega) + (\omega - \gamma_0^{-1} \sin(h\omega))}{(\beta + \gamma_0^{-1} \cos(h\omega)) + \alpha \gamma_0^{-1} \omega \sin(h\omega)} \right) \\ &\quad - \tan^{-1} \left(\frac{\gamma_0^{-1} \alpha \omega \cos(h\omega) - (\omega - \gamma_0^{-1} \sin(h\omega))}{(\beta + \gamma_0^{-1} \cos(h\omega)) - \alpha \gamma_0^{-1} \omega \sin(h\omega)} \right) \end{aligned} \quad (3.21)$$

where $\omega = \sqrt{\frac{(\gamma_0 K)^2 \alpha_1^2 - \gamma_2^2 \beta_1^2}{\gamma_2^2 - (\gamma_0 K)^2}}$. After finding $\gamma_{2,opt}$, we can write the $C_{2,opt}$ as,

$$C_{2,opt}(s) = A(s) \frac{1}{1 - D_c(s)B(s)} \quad (3.22)$$

where,

$$A(s) = \frac{(\gamma_0^2 K^2 \alpha_1^2 - \gamma_{2,opt}^2 \beta_1^2) + (\gamma_{2,opt}^2 - \gamma_0^2 K^2) s^2}{\gamma_0 K \gamma_{2,opt} (\beta_1 + s) (\alpha_1 + s)}$$

$$B(s) = \left(\frac{\gamma_{2,opt}}{\gamma_0 K} \right) \left(\frac{\beta_1 - s}{\alpha_1 + s} \right).$$

In order to calculate $\widehat{Q}_{2,opt}(s)$ corresponding to $C_{2,opt}(s)$, we will use the transformation

$$\widehat{Q}_{2,opt}(s) = \frac{C_{2,opt}(s)}{1 + P(s)C_{2,opt}(s)}.$$

That gives

$$\begin{aligned} \widehat{Q}_{2,opt}(s) &= A(s) \frac{1}{1 - D_c(s)B^{-1}(-s)} \\ &= \frac{(\gamma_0^2 K^2 \alpha_1^2 - \gamma_{2,opt}^2 \beta_1^2) + (\gamma_{2,opt}^2 - \gamma_0^2 K^2) s^2}{\gamma_0 K \gamma_{2,opt} (\beta_1 + s) (\alpha_1 + s)} \frac{1}{1 - D_c(s) \left(\frac{\gamma_0 K}{\gamma_{2,opt}} \right) \left(\frac{\alpha_1 - s}{\beta_1 + s} \right)} \end{aligned} \quad (3.23)$$

After finding $\widehat{Q}_{2,opt}(s)$, $F(s)$ can be calculated via (3.14),

$$F(s) = -(\widehat{Q}_{2,opt}^{-1}(s) + C_{opt}^{-1}(s))$$

where $\widehat{Q}_{2,opt}(s)$ and $C_{opt}(s)$ are found in (3.23) and (3.8) respectively.

Similarly, the resulting controller $K(s)$ is determined as

$$K(s) = -\widehat{Q}_{2,opt}(s)$$

which is shown in (3.15).

Recall that the largest value of $|N_p(j\omega)|$, for which K becomes a strongly stabilizing controller for $P = M_p N_p$, is

$$|N_p(j\omega)| < |K(j\omega)|^{-1}.$$

It is also possible to blend this condition with the largest allowable sensitivity deviation condition. That would result in a two block \mathcal{H}^∞ problem (which is slightly more difficult to solve by hand calculations that are similar to those we have done in this section). We refer to the full version of the paper, [15], for the details and a numerical example.

4 Conclusions

In this paper we have considered \mathcal{H}^∞ control of a class of systems with infinitely many right half plane poles. We have demonstrated that the problem can be solved by using the existing \mathcal{H}^∞ control techniques for infinite dimensional systems with finitely many right half plane poles. Connections with strong stabilization are made, and we have seen an indirect design method for stable controllers achieving a desired sensitivity, for infinite dimensional plants (in particular systems with time delays). There are alternative direct methods of designing F , or an appropriate K . Comparisons of different design methods will be made with examples in the full version of our paper.

References

- [1] M. Vidyasagar, *Control System Synthesis: A Factorization Approach*, MIT Press, 1985.
- [2] A. Sideris, and M. G. Safonov, "Infinity-norm optimization with a stable controller," *Proc. American Control Conf.*, 1985, 804-805.
- [3] A. E. Barabanov, "Design of \mathcal{H}^∞ optimal stable controller," *Proc. Conf. Decision and Control*, 1996, 734-738.
- [4] M. Jacobus, M. Jamshidi, C. Abdullah, P. Dorato, and D. Bernstein, "Suboptimal strong stabilization using fixed-order dynamic compensation," *Proc. American Control Conf.*, 1990, 2659-2660.
- [5] H. Ito, H. Ohmori, and A. Sano, "Design of stable controllers attaining low \mathcal{H}^∞ weighted sensitivity," *IEEE Tran. Automat. Contr.* 38, 1993, 485-488.
- [6] C. Ganesh, and J. B. Pearson, "Design of optimal control systems with stable feedback," *Proc. American Control Conf.*, 1986, 1969-1973.
- [7] M. Zeren, and H. Özbay, "On the synthesis of stable \mathcal{H}^∞ controllers," *IEEE Tran. Automat. Contr.* 44, 1999, 431-435.
- [8] M. Zeren and H. Özbay, "On the strong stabilization and stable H^∞ -controller design problems for MIMO systems," *Automatica* 36, 2000, 1675-1684.
- [9] D. U. Campos-Delgado, and K. Zhou, " \mathcal{H}^∞ Strong stabilization," *IEEE Tran. Automat. Contr.* 46, 2001, 1968-1972
- [10] D. S. Flamm, and S. K. Mitter, " \mathcal{H}^∞ sensitivity minimization for delay systems," *Systems & Control Letters* 9, 1987, 17-24.
- [11] K. E. Lenz, "Properties of optimal weighted sensitivity designs," *IEEE Tran. Automat. Contr.* 40, 1995, 298-301.

- [12] M. C. Smith, “On Stabilization and the existence of coprime factorizations,” *IEEE Tran. Automat. Contr.* 34, 1989, 1005-1007.
- [13] C. Foias, H. Özbay, and A. Tannenbaum, *Robust Control of infinite Dimensional Systems: Frequency Domain Methods*, No.209 in LNCIS, Springer-Verlag, 1996.
- [14] O. Toker and H. Özbay, “ H^∞ Optimal and suboptimal controllers for infinite dimensional SISO plants,” *IEEE Transactions on Automatic Control* 40, 1995, 751–755.
- [15] S. Gümüşsoy and H. Özbay, “An indirect approach to strong stabilization of infinite dimensional plants,” in preparation 2002.